

1. DESIGN CRITERIA

- 1.A. THE TANK AND SUPPORT STRUCTURE SHALL BE DESIGNED, FABRICATED, AND ERECTED IN ACCORDANCE WITH AWWA D107-10 AND THE PROJECT SPECIFICATIONS.
- 1.B. LOADING CRITERIA:
  - 1.B.A. DESIGN WIND VELOCITY - \_\_\_\_\_ MPH
  - 1.B.B. DESIGN SNOW LOAD - \_\_\_\_\_ PSF
  - 1.B.C. MCE SPECTRAL RESPONSE ACCELERATION - 0.2 - SEC PERIOD (S<sub>3</sub>) - \_\_\_\_\_
  - 1.B.D. MCE SPECTRAL RESPONSE ACCELERATION - 1.0 - SEC PERIOD (S<sub>1</sub>) - \_\_\_\_\_

2. MATERIALS

- 2.A. STEEL PLATE: ASTM A283 OR ASTM A36
- 2.B. STRUCTURAL SHAPES: ASTM A36
- 2.C. LADDER RUNGS: ASTM A706

3. GENERAL

- 3.A. ALL ACCESSORIES SHOWN ON THE ELEVATION DRAWING ARE ROTATED FOR CLARITY.
- 3.B. ALL LADDERS, LADDER SAFETY DEVICES, PLATFORMS, HANDRAILS, ETC. SHALL CONFORM TO CURRENT OSHA REGULATIONS.
- 3.C. SURFACE PREPARATION AND COATING REQUIREMENTS SHALL BE IN ACCORDANCE WITH THE PROJECT SPECIFICATIONS.
- 3.D. THE TANK SHALL BE DISINFECTED IN ACCORDANCE WITH AWWA C652-02.

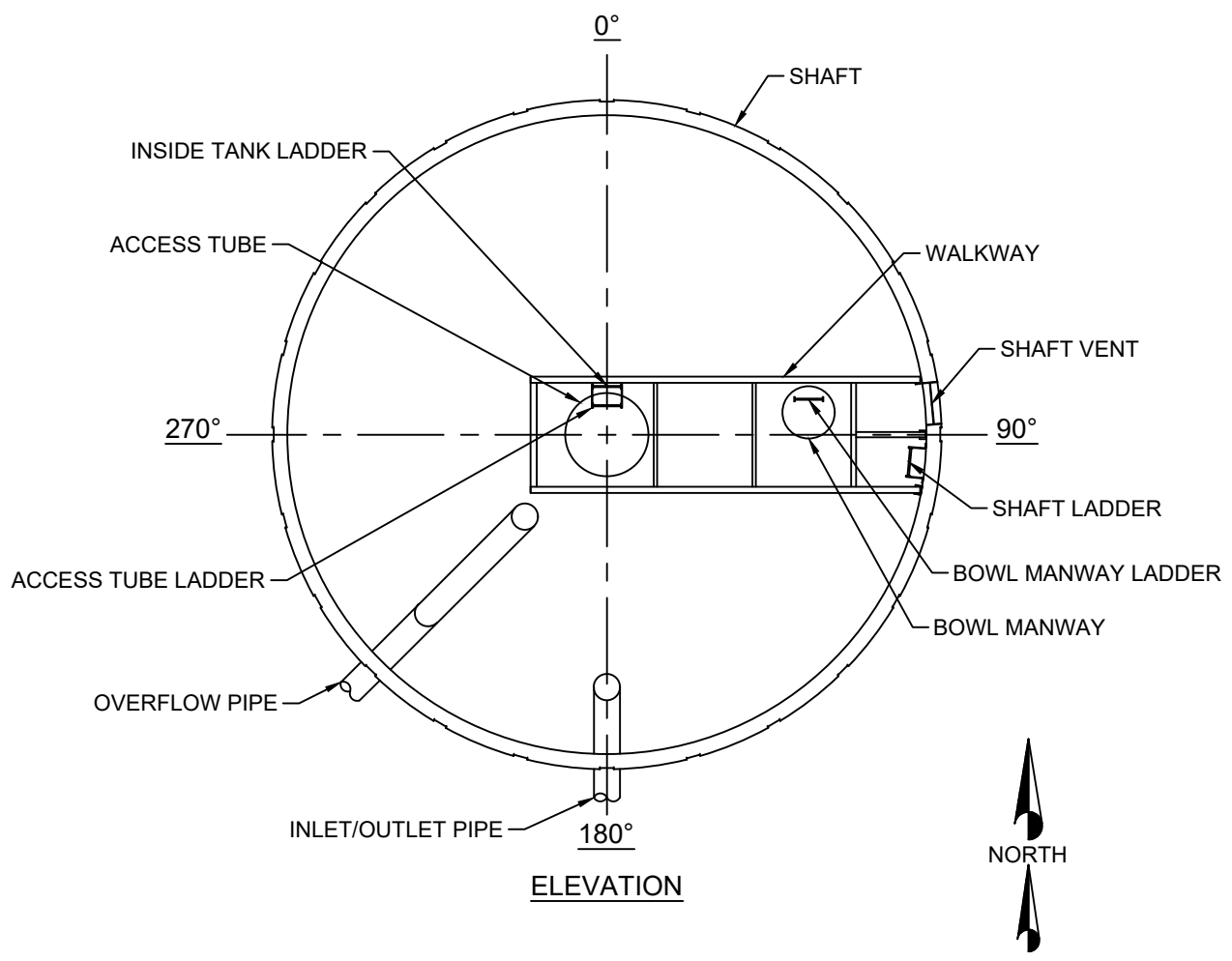

150,000 GALLON ELEVATED COMPOSITE TANK		Revision Description
<b>GENERAL ELEVATION</b>		Rev. By Rev. Date
		Copyright © 2017 by Phoenix Fabricators & Erectors, LLC. All rights reserved.
Engineer:	Checked By:	Date:
 Avon, Indiana - Seebree, Kentucky		
JOB. No.		
SHEET		