

1. DESIGN CRITERIA
 - 1.A. THE TANK AND SUPPORT STRUCTURE SHALL BE DESIGNED, FABRICATED, AND ERECTED IN ACCORDANCE WITH AWWA D107-10 AND THE PROJECT SPECIFICATIONS.
 - 1.B. LOADING CRITERIA:
 - 1.B.A. DESIGN WIND VELOCITY - _____ MPH
 - 1.B.B. DESIGN SNOW LOAD - _____ PSF
 - 1.B.C. MCE SPECTRAL RESPONSE ACCELERATION - 0.2 - SEC PERIOD (S_s) - _____
 - 1.B.D. MCE SPECTRAL RESPONSE ACCELERATION - 1.0 - SEC PERIOD (S_1) - _____
2. MATERIALS
 - 2.A. STEEL PLATE: ASTM A283 OR ASTM A36
 - 2.B. STRUCTURAL SHAPES: ASTM A36
 - 2.C. LADDER RUNGS: ASTM A706
3. GENERAL
 - 3.A. ALL ACCESSORIES SHOWN ON THE ELEVATION DRAWING ARE ROTATED FOR CLARITY.
 - 3.B. ALL LADDERS, LADDER SAFETY DEVICES, PLATFORMS, HANDRAILS, ETC. SHALL CONFORM TO CURRENT OSHA REGULATIONS.
 - 3.C. SURFACE PREPARATION AND COATING REQUIREMENTS SHALL BE IN ACCORDANCE WITH THE PROJECT SPECIFICATIONS.
 - 3.D. THE TANK SHALL BE DISINFECTED IN ACCORDANCE WITH AWWA C652-02.

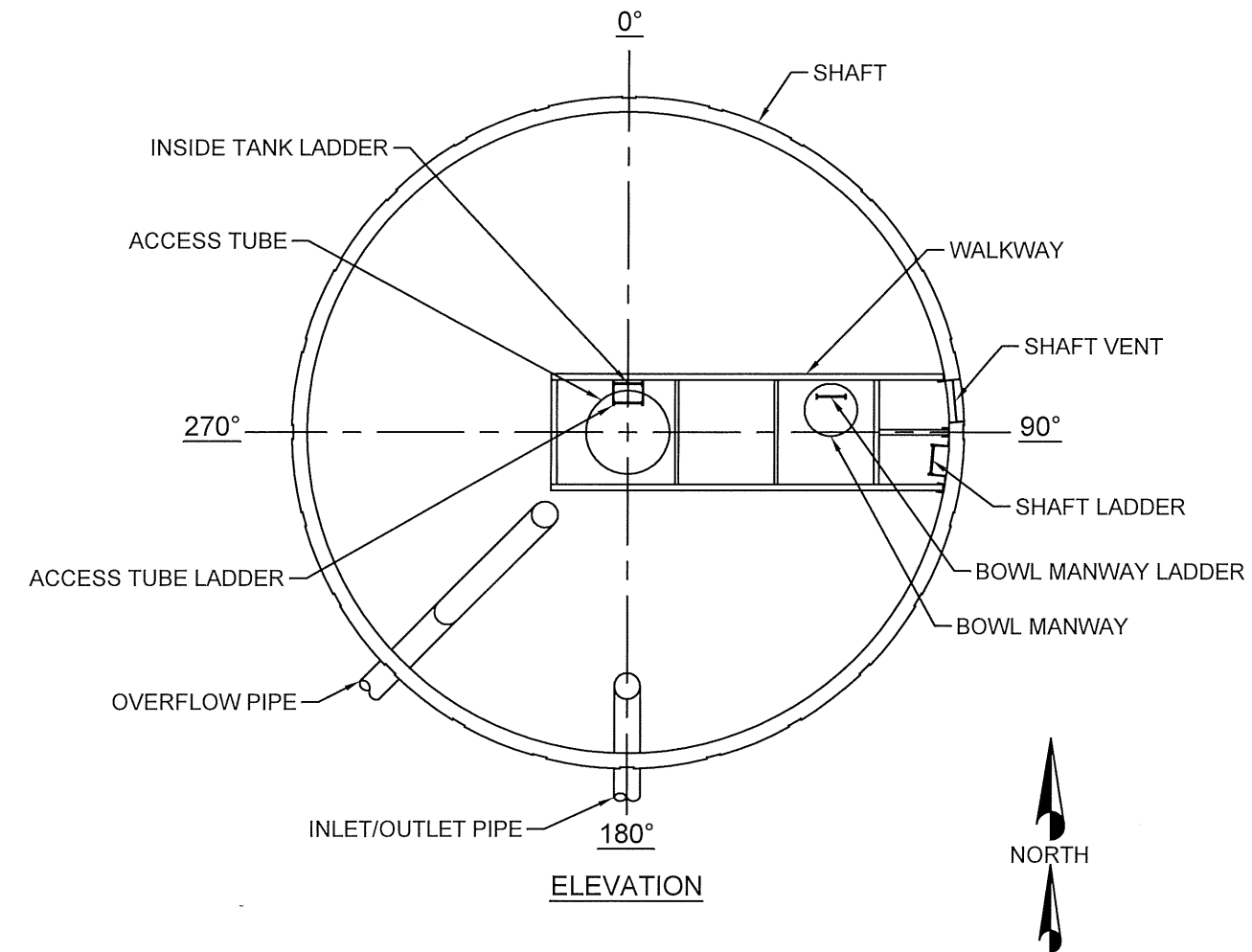

2,000,000 GALLON ELEVATED COMPOSITE TANK	Revision Description
GENERAL ELEVATION	Rev. By Rev. Date
Engineer:	Checked By:
Drawn By:	Date:
 Avon, Indiana - Seebree, Kentucky	
JOB. No.	
SHEET	